

EASY – Efficient Agriculture Systems



EASY. Together. Simple. Better.

The combined electronics expertise of CLAAS can be summed up in a single word: EASY. This stands for Efficient Agriculture Systems, and lives up to its name. From machine optimisation with CEMOS AUTOMATIC through steering systems and fleet management with TELEMATICS to farm management software, EASY makes it all simple. Your systems can be matched perfectly with each other, enabling you to get the best performance from your machines and drivers and top results for your business.





- Farm management software** 6
- Software solutions 8
- Mobile applications (apps) 10

- Crop protection and fertiliser application** 12
- Precise field functions 14

- CEMOS** 18
- Machine optimisation 20

- CLAAS terminals** 28

- TELEMATICS** 32
- Data management 34



A certain degree of business acumen is crucial for successful farming – it's essential to maximise potential in all areas, optimise processes and utilise resources more effectively. CLAAS offers intelligent software solutions to support you in your work.

Building on a strong foundation. Your farm data.

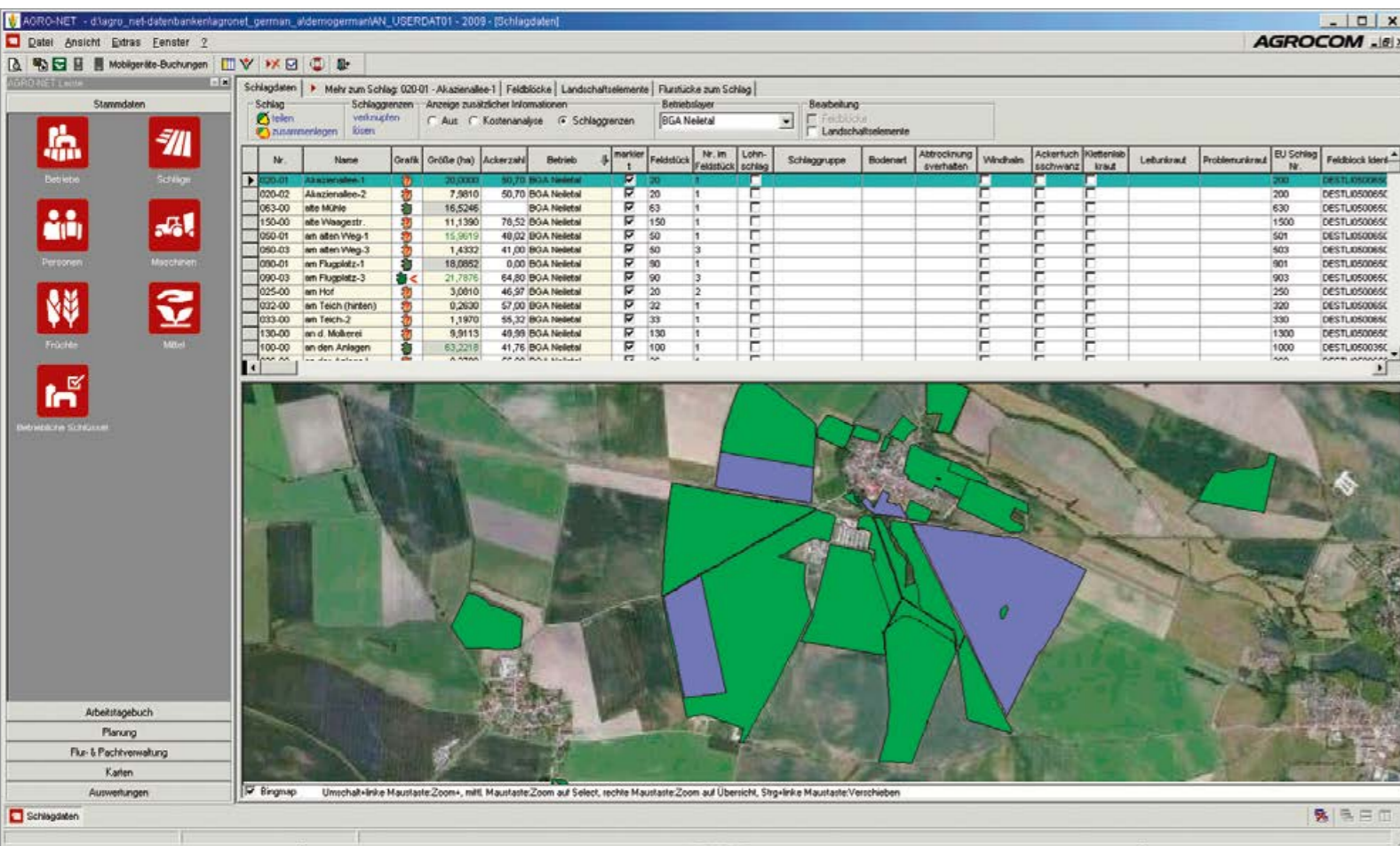

AGROCOM NET – management software – more important to your farm than ever before.

The amount of automatically gathered data is constantly growing. Machine terminals collect data all the time – but they also need the appropriate master data, such as field boundaries and inputs used, which is sent to the machine from the office. Increasingly stringent regulations in the areas of crop protection and fertiliser application make the AGROCOM NET farm management software an indispensable tool on your farm. From simple record keeping and documentation to more advanced functions such as reference track management, creating application maps and field management, the potential applications are as diverse as the challenges that agriculture must address in order to remain profitable and up to date.

A modular structure and expandability are therefore particularly important.

AGROCOM NET, the crop production management solution from CLAAS, offers all of this.

Naturally, AGROCOM NET doesn't just come as a desktop version for the PC. It is also available as the AGROCOM NET app, a mobile version which allows you to process documentation wherever you are.

AGROCOM MAP – the precision farming specialist.

AGROCOM MAP specialises in the areas of machine deployment, yield maps and precision farming. With this PC program, all the operations involved in precision farming can be carried out quickly and straightforwardly in an easy-to-understand way. AGROCOM MAP is also modular in structure – you can start with a basic version and expand it into a complete precision farming tool by adding different modules.



365FarmNet – nothing missing.

The web-based 365FarmNet software brings many agricultural management requirements together in one place and automatically integrates the functions of various agricultural apps which are essential for modern farm management. 365FarmNet currently provides support for farmers in crop production. Herd management for dairy production will follow soon, and it will also cover the contracting, pig, forestry and biogas sectors. In future, all business situations will be supported.

Integration with TELEMATICS will enable our customers to use the relevant machine data (yields, application rates, consumption figures, times, etc.) directly in the farm management software.

The field route optimisation function allows you to optimise driving strategies in the field. Depending on working width, it calculates the optimum pass strategy which involves the shortest distance and the shortest time. At the same time, field route optimisation can be used to plan the most cost-effective working widths for the farm.

CLAAS is a partner in 365FarmNet and is developing a number of services which communicate directly with 365FarmNet.



Increased productivity directly in the field.

Whole-field management is still the predominant farming system in most regions. In this approach, the fertiliser or pesticide application rate is not adjusted to suit varying conditions within the field. The aim of conventional precision farming is to respond to differing conditions within the field (growth, nitrogen supply, soil type) by adjusting the application rate.



Inch-perfect work. Steering systems.



GPS PILOT.

The GPS PILOT uses a satellite signal to guide the machine securely and effortlessly along parallel tracks. The system helps the operator to utilise the machine's full working width and reduces overlapping, producing a higher quality of work in a shorter time regardless of light or weather conditions.



AUTO TURN.

With the AUTO TURN function the machine turns automatically at the headland, enabling you to line up with your selected track faster and more accurately, avoid overlaps and concentrate on the implement settings. The virtual headland line in the S10 makes AUTO TURN even more convenient.

TURN IN.

The TURN IN function makes it easier to line up on the headland. TURN IN quickly identifies the right track and steers into the new track more accurately than is possible manually.

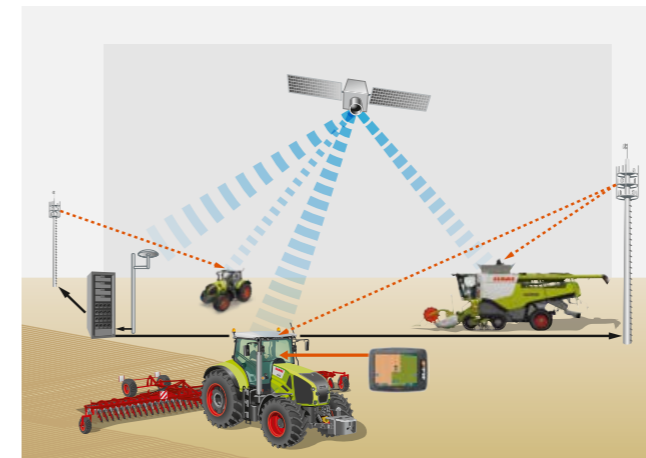

Correction signals.

Positioning by GPS, GLONASS and, in future, GALILEO alone rarely meets the demands of modern farming. CLAAS therefore offers an extensive range of correction signals. From satellite-based EGNOS signals (+ / - 15-30 cm) through OMNISTAR HP / XP / G2 (+ / - 5-10 cm) to RTK Field Base terrestrial reference stations (2-3 cm), RTK base station (2-3 cm) and the mobile phone version RTK NET (2-3 cm), we have the perfect correction signals to meet every requirement.

Variable rate application. Crop protection and fertiliser application.

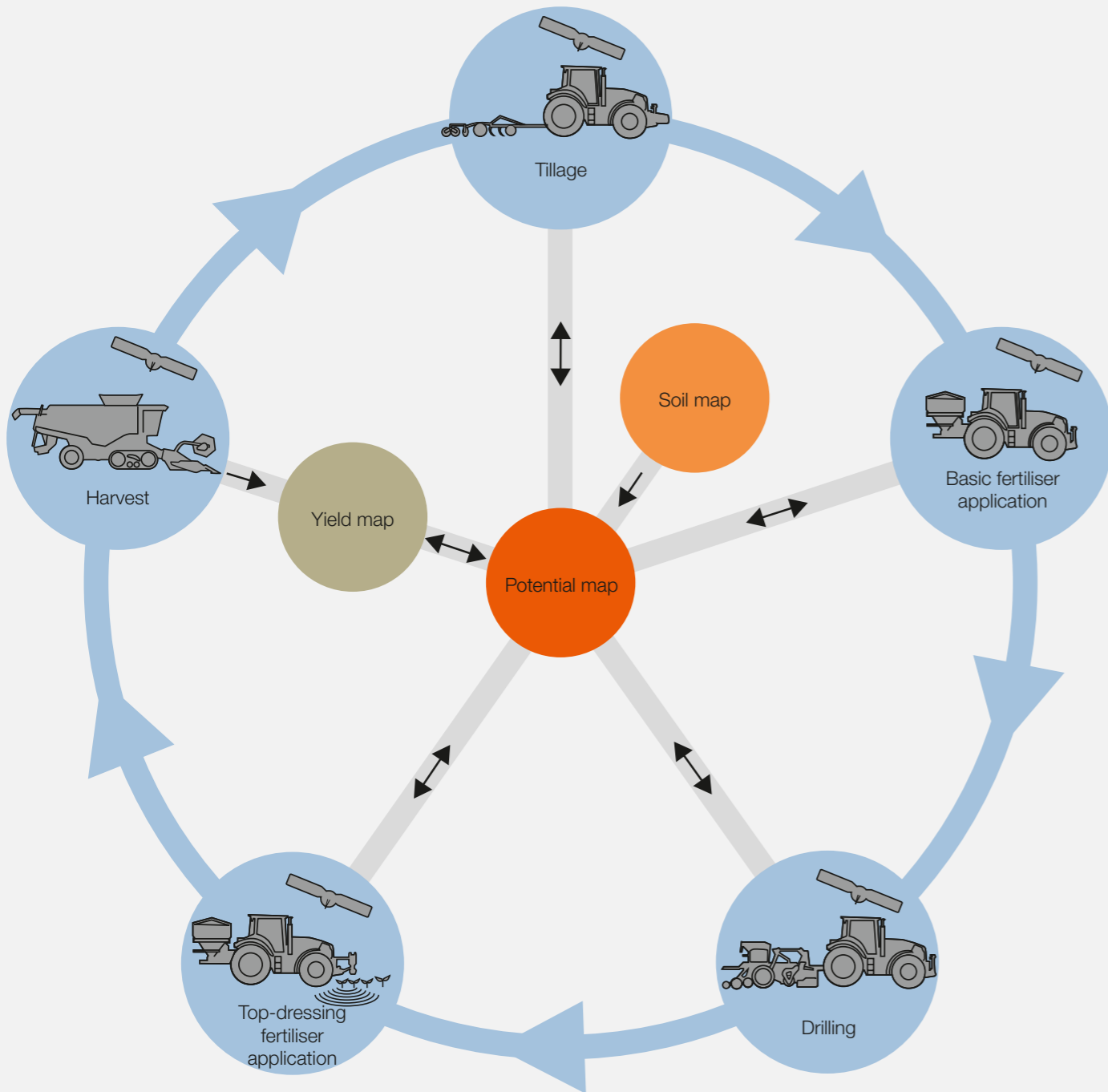

CROP SENSOR.

CROP SENSOR is the first AEF-certified, fully ISOBUS-compatible crop sensor on the market. The CROP SENSOR is an online tool which optimises application of N fertilisers, growth regulators and crop protection products in a variety of crops.

An optimum nitrogen supply has a significant impact on yield and quality. You only apply the amount that the crop needs – which saves resources.



Variable application rate control.

Yield maps, biomass maps, potential soil moisture maps, results of soil mapping and other relevant geodata. A huge amount of geo-information is now available in agriculture, opening up a wide range of possibilities for farmers, and site-specific or variable rate application of seed, fertilisers and pesticides is now possible simply by combining application maps and implements with suitable terminals. The S10 terminal from CLAAS is the perfect ISOBUS solution for variable rate application and GPS steering.

ISOBUS Section Control.

For drilling, fertiliser application and crop protection, the golden rule is as much as necessary and as little as possible. This is the best way of managing the farm economically and ecologically. In the AEF-standardised ISOBUS Section Control function, the sections of the implement are switched on and off to prevent overlapping, so that inputs are only applied where they are needed.

Section Control will be available as a function on the S10 terminal from October 2016.



CEMOS. Optimum use of machine capacity.

Maintaining quality of work and seasonal performance at a constantly high level is always a challenge and depends on many factors, especially the driver's skills and "form" on the day. CEMOS (CLAAS electronic machine optimisation system) supports the driver during long working days and helps to fully exploit the performance potential of the machine.



CEMOS. Good advice all the time.



CEMOS.

The CEMOS (CLAAS electronic machine optimisation system) concept from CLAAS includes all the systems that optimise machine performance.

CEMOS can be divided into two different areas:

- 1 Dialogue-based systems:
CEMOS DIALOG or CEMOS Advisor. These systems guide the driver step by step to the optimum machine configuration. The driver must confirm or apply the suggested settings.
- 2 Automatic systems:
CEMOS AUTOMATIC is an umbrella term for all the functions that optimise the machine automatically. With the CEMOS AUTOMATIC functions, the machine automatically adjusts the settings so that the machine can be used to its full capacity. The driver's job becomes much easier, making it possible to work effectively with CEMOS AUTOMATIC throughout long working days.



CEMOS Advisor app.

The CEMOS Advisor app from CLAAS acts as the farmer's automatic assistant, finding the correct combine harvester setting every time. CEMOS Advisor guides you through the optimisation process by asking simple questions. After every

change to the settings, the driver can check the result and request further optimisation suggestions if necessary. CEMOS Advisor helps make good drivers even better.

CEMOS DIALOGUE.

CEMOS DIALOG is a convincing, reliable partner for the operator, motivating him/her to optimise combine performance by adapting the settings to the situation, providing a sense of security and increasing skills through ongoing learning.

The operator assistance system runs on the external terminal (CEBIS MOBILE). CEMOS DIALOG guides the operator to the best machine configuration by suggesting improvements.

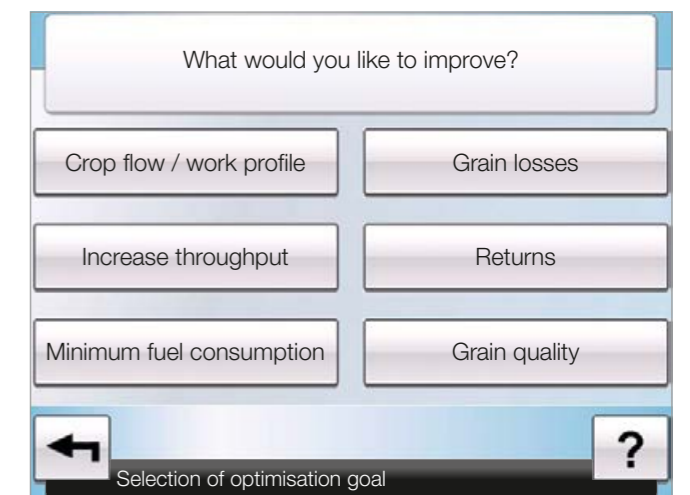

CEMOS. Clean work, always.



GRAIN QUALITY CAMERA.

Clean grain – automatically.

The combination of the GRAIN QUALITY CAMERA with the two CEMOS AUTOMATIC functions – AUTO CLEANING and AUTO SEPARATION – means that CLAAS has set a new milestone on the way to the automation of combine harvesting. The GRAIN QUALITY CAMERA evaluations now have an active influence on the AUTO CLEANING and AUTO SEPARATION functions of the CEMOS AUTOMATIC system.

How it works:

The evaluation by the GRAIN QUALITY CAMERA shows the proportion of broken grains as well as the proportion of non-grain constituents (NGC). The NGC is shown on the CEBIS screen in graphical form, either directly in the live image or in the harvest display. The operator can set the required level of grain cleaning by adjusting the NGC sensitivity. AUTO CLEANING and AUTO SEPARATION now optimise the cleaning and residual grain separation continuously if the desired level has not yet been attained. The GRAIN QUALITY CAMERA can be switched on and off in CEBIS.



CEMOS AUTO SEPARATION.

The ROTO PLUS residual grain separation system in the LEXION 700 series has two configuration options which have a significant impact on the machine's overall throughput: continuously variable adjustment of rotor speed and adjustment of the separation area by opening and closing the rotor flaps.

CEMOS AUTO SEPARATION utilises these options automatically and continuously, reflecting the prevailing field conditions. As a result, the machine automatically achieves maximum throughput with top grain quality, outstanding grain cleanliness and minimum fuel consumption.

CEMOS AUTO SEPARATION is the operator assistance system that finds the right settings every time.

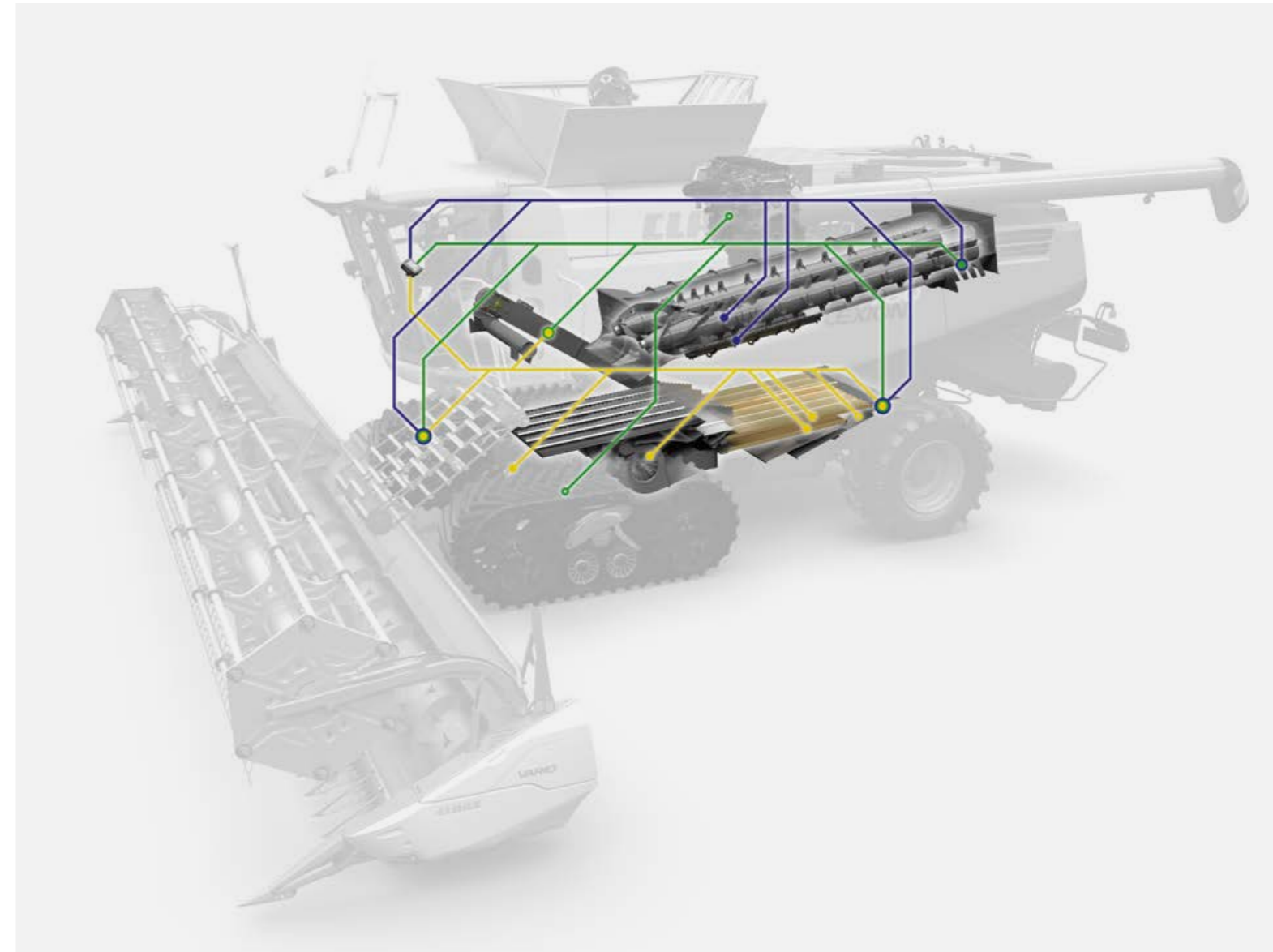

CEMOS AUTO CLEANING.

CEMOS AUTO CLEANING automatically and continuously adjusts the upper sieve and lower sieve as well as the fan speed in accordance with the prevailing field conditions and terrain. The following parameters are therefore measured and taken into account:

- Throughput monitoring, cleaning
- Throughput monitoring, straw walker
- Returns volume

- Composition of returns (grain and non-grain constituents)
- CRUISE PILOT (crop volume in feeder housing)
- Incline sensor

In this way, CEMOS AUTO CLEANING minimises cleaning losses while maximising grain cleanliness.

CEMOS. Harvesting instead of adjusting.

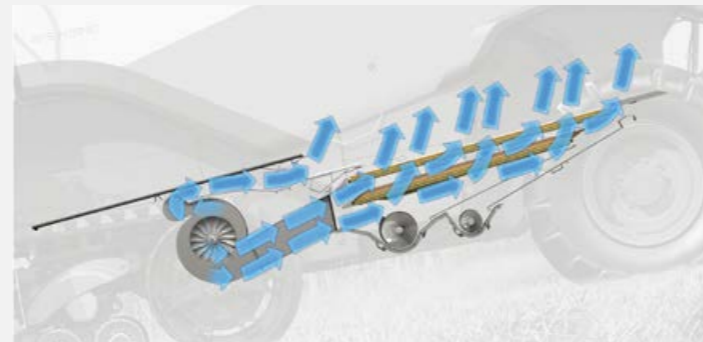

CEMOS AUTO SLOPE.

Hilly terrain calls for extra concentration on the part of the operator. This is precisely why the AUTO SLOPE function helps the operator to adjust the cleaning system. If the machine is operating uphill, the fan speed must be reduced in order to avoid grain losses from the sieve pan. On the other hand, during downhill operation, the fan speed must be

increased to maintain the crop flow in the cleaning system and so ensure that the grain is separated.

AUTO SLOPE now adjusts the fan speed to the conditions, the starting point being the fan speed set beforehand by the operator.

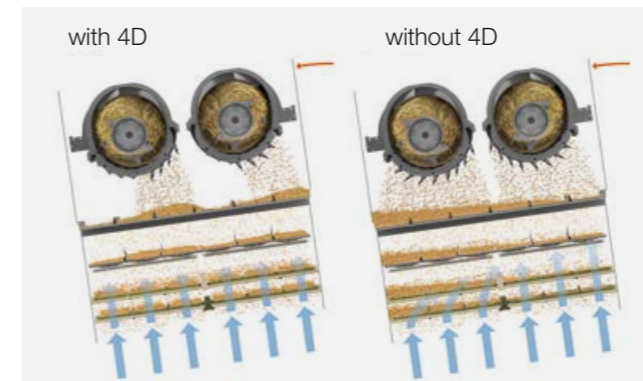

4D cleaning.

Using the machine to harvest fields which are not level presents the cleaning system with a particular challenge. With the machine running along a side slope, the material in the residual grain separation system moves to the side of the returns pan closest to the bottom of the slope. As a result, the preparation floor and the sieves are loaded on one side only. And when the machine is running up or downhill, the fan speed and the sieve position have to be adjusted in order to attain the optimum cleaning performance and avoid losses.



LASER PILOT.

The LASER PILOT locates the crop edge and guides the machine through the field with razor-sharp precision. The system is highly reliable in all weather conditions, independent of GPS or radio signals.



CAM PILOT.

CAM PILOT is based on digital 3D image analysis. The camera recognises the 3D structure of the swath and steers the JAGUAR during grass harvesting with the PICK UP. The swaths are accurately detected and steering follows automatically. Working speeds of up to 15 km/h can be achieved. The CAM PILOT is easily activated by a button on the control lever.



Yield mapping.

Building on the foundation of the job management functions, you can use your LEXION or JAGUAR to perform yield mapping. Sensors in the machine measure the yield and grain moisture while CEBIS adds geographic coordinates using GPS satellite data.

CEMOS.

A precise response every time.



AUTO FILL.

AUTO FILL is based on digital 3D image analysis. By analysing camera images of the accompanying trailer, the system is able to determine both the outer edges and the fill volume at every point within the trailer.

It can also identify the point of impact of harvested crops entering the trailer. The results are used to regulate the longitudinal and transverse position of the discharge spout relative to the vehicle axis



AUTO PILOT.

The mechanical sensor brackets detect the position of the plant, send signals to the steering unit and guide the machine automatically along the crop rows.

The AUTO PILOT allows loss-free operation even in poor visibility and at high working speeds, significantly reducing operator fatigue.



Implement controls tractor (ICT).

The ICT CRUISE PILOT automatically regulates the tractor's travel speed on the basis of CARGOS / QUADRANT 3400 performance. This makes it easier to operate the machine and reduces the driver's workload. At the same time, the capabilities of the CARGOS / QUADRANT 3400 are utilised to the full as downtime due to overloading of the loading assembly is eliminated. If the loading assembly on the

CARGOS / QUADRANT 3400 does become blocked despite ICT CRUISE PILOT, the ICT AUTO STOP automatically clears the blockage and protects the PTO.

This function makes the machine easier to operate as it does away with the manual routines that were previously required and the system automatically starts to clear the blockage in the loading assembly.

The right choice.
Our terminals.

Whether you want a terminal with ISOBUS functions and GPS steering, ISOBUS implement control, a simple operating terminal for CLAAS implements or an up-to-date tablet app for ISOBUS implement control and job management, CLAAS offers just the right terminal for every size of farm and every type of work.





S10



S10 terminal.

The S10 is a CLAAS terminal for professional users. It has a large, high-resolution 10.4-inch touchscreen and features an extensive range of functions. With the S10 you can operate the steering system while at the same time controlling ISOBUS functions and connecting up to four analogue cameras, such as the CLAAS PROFI CAM. Naturally, functions can also be assigned to the F buttons (auxiliaries).

S7



S7 terminal.

The S7 basic terminal has all the latest technology and is the right choice if you just want to use your terminal to control a parallel guidance or automatic steering system. With its high-resolution 7" touchscreen, the S7 performs all the functions provided by its predecessor, the S3.

COMMUNICATOR



COMMUNICATOR.

The COMMUNICATOR terminal has a 5.7" colour display. It conforms to the ISO UT standard, allowing convenient control of ISOBUS-compatible implements from the COMMUNICATOR. Naturally, functions can also be assigned to the F buttons (auxiliaries).

OPERATOR



OPERATOR.

The OPERATOR features an impressive, self-explanatory user interface and straightforward customer management. 20 job memories are available for guaranteed flexibility. The function buttons are also backlit. The OPERATOR requires an ISOBUS-enabled CLAAS implement.



EASY on board app.

With the new EASY on board app, all ISOBUS-compatible implements can be controlled from a tablet (from iPad 3 / iPad air / air2 / iOS 8). For even greater convenience, various functions can be assigned to the F buttons (auxiliaries) as with any other ISOBUS terminal.

The convenience of tablet-based operation is matched by its reliability. With the USB interface, a fast and reliable power supply to the tablet is guaranteed over long periods in the field. What's more, using a tablet reduces clutter in the cab.

The full picture. All the time.

TELEMATICS features a user-friendly design and an intuitive control system, enabling you to keep track of all your machine data all the time. You can also choose from three different packages (basic, advanced and professional) which allow TELEMATICS to grow with your requirements.



Simply better performance. TELEMATICS.



Work diary detail

General specifications

Location	Bäckerkamp
Machine	C8599999
Farm	Wiggen
Activity	Combining
Crop	Wheat
Fuel consumption	444.50 l
Spec. fuel consumption.	2.63 l/t

Times	Areas/yields		
Start of value	03/08/2014, 10:52:30	Location area	24.95 ha
End of work	03/08/2014, 17:55:04	Area segment	64 %
Time at the location	7:03 h	Crop yield	169.08 t
Eff. working hours	5:18 h	Length of cut	
		Area counter (area worked)	15.98 ha
		Average moisture	14.60 %
		Yield	10.58 t/ha

Implement

Front attachment type:

Working width: 10.5 m

Back Export AFT Export ISO-XML Print Save

Automatic documentation.

Automatic documentation is an extension to TELEMATICS. Without any intervention by the machine operator, work data relating to the specific fields worked is transferred to the server, where it is interpreted and processed. All machine-relevant data can be exported in IsoXML format.

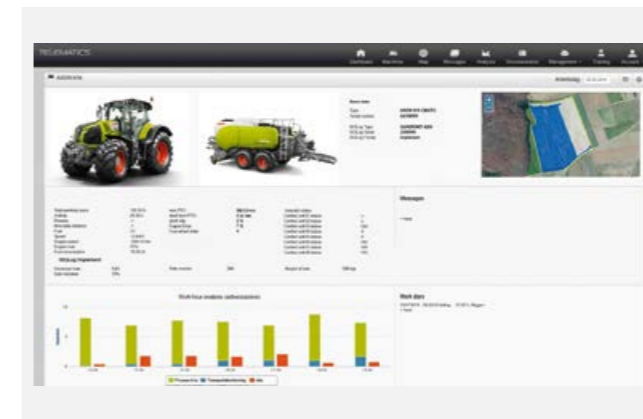

TELEMATICS on Implement (TONI).

TONI enables you to capture all the tractor-relevant data as well as all the machine data for the attached implement.

This technology is not restricted to CLAAS machines as implements from other manufacturers are also TONI-enabled.

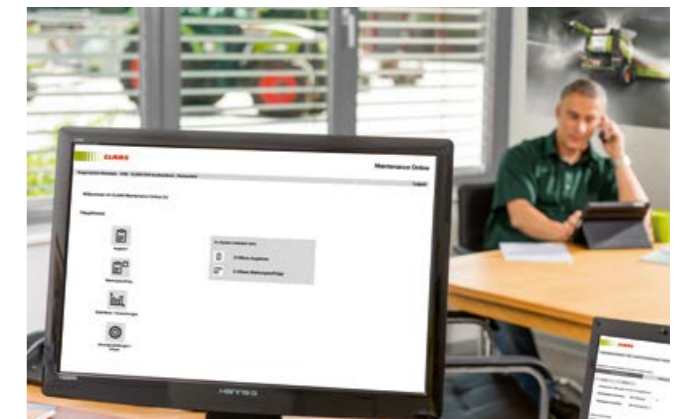

Remote diagnostics.

Save valuable time with CLAAS remote diagnostics. This outstanding feature grants service staff direct access to all your machine's performance and electronics data via the internet. If a problem does arise, our staff can often find a solution remotely. And if a problem requires an on-site visit, our staff have all the information they need and will bring the necessary spare parts with them.



TELEMATICS app.

To enable you to use TELEMATICS when you are out and about, CLAAS offers a smartphone app for iOS and Android operating systems. The operating philosophy behind the app is the same as for the website and guides you through the three steps in modern fleet management: inform, analyse, optimise.

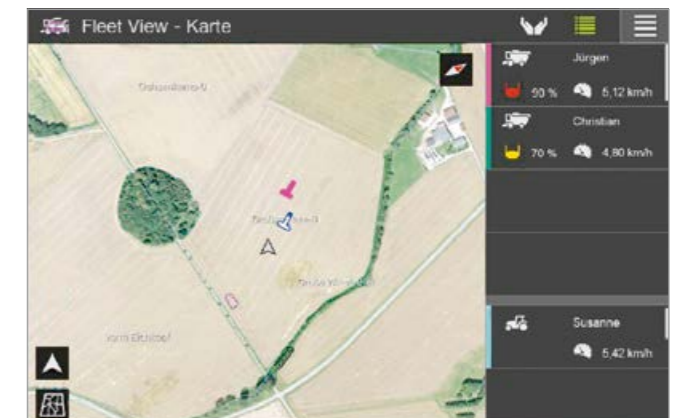

Fleet View app.

The Fleet View app from CLAAS enables you to coordinate the grain transport team in your harvesting fleet so that your combine harvesters can keep on working without downtime. The app continuously informs all the drivers in a logistics chain almost in real time about the positions of the combine harvesters in the fleet and their current grain tank fill levels.



Ensuring a better **harvest.**

CLAAS KGaA mbH
Postfach 1163
33416 Harsewinkel
Deutschland
Tel. +49 5247 12-0
claas.com

731012000616 KK DC 0816 / 00 0259 544 3